

Dragonfish Standard

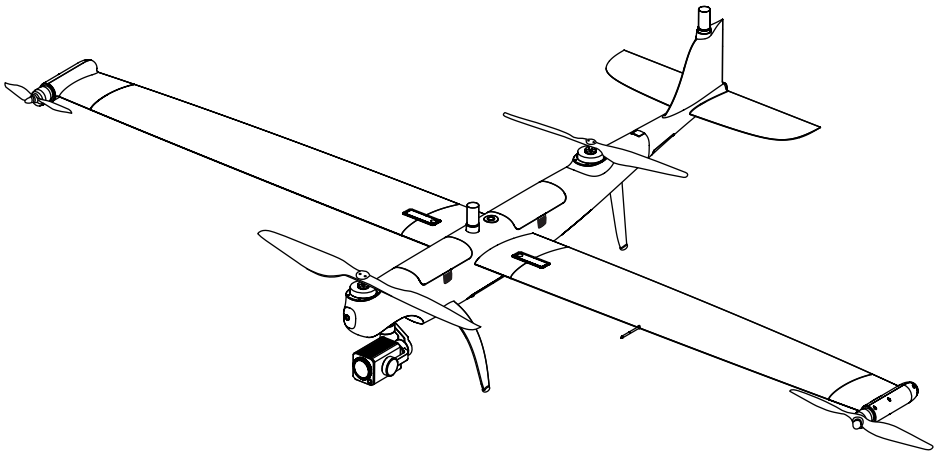









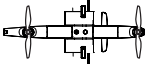



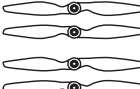



Quick Start Guide

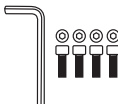
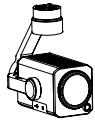
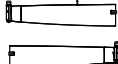

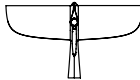
Contents

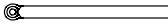
Item list	2
Getting to know the aircraft	3
Getting to know the mobile ground station	4
Getting to know the base station	4
Using the Drgonfish Standard aircraft	5
Charging	5
Setting up the base station	5
Assembling the aircraft	6
Powering on / Activating the aircraft	8
Powering on the base station	8
Powering on the ground station	8
Powering on the aircraft	8
Activating the aircraft	8
Flight	9
Activating the aircraft	9
Automatic takeoff	10
Specifications	11

Item list

	Aircraft body x 1		9.7 inch ground station x 1
	Base station x 1		Battery x4 (the actual quantity is subject to the purchased set)
	Charger + AC line x 1		Propeller blades x 2
	Base station antenna x 2		Base station feeder x 2
	Base station tray x 1		Base station tripod x 1
	Base station charger x 1		USB Type-C cable x 1
	Repair tool kit x 1		Gimbal Camera x 1 (The gimbal model is subject to the actual set purchased)
	Wing set x 1		Ground station lanyard x 1
	Tail x 1		Propeller holder x 2
	Airspeed indicator cover x 1		TF card x 1
	Tail Rubber Cover x 1		Documentation x 1 set (includes Drgonfish Standard, Base station, Charger, Battery quick guide, Disclaimer)

Getting to know the aircraft

The Drgonfish Standard aircraft integrates Autel Robotics' intelligent and superior flight control technology, gimbal technology, and imaging technology. The aircraft boasts a new tilt rotor design that combines the efficiency of fixed-wing aircraft endurance with the takeoff convenience of traditional multi-rotor drones. A 5 second self-check system ensures the aircraft is safe and ready for operation. It can be assembled quickly, enabling set up and take-off in a matter of minutes. The Drgonfish Standard offers a maximum flight time of up to 120 minutes and a video transmission range of 30 km. It comes built in with a range of intelligent features such as automatic take-off and landing, intelligent tracking, terrain follow and more.

Tough and reliable, the Drgonfish Standard has an IP43 protection rating to enable operations across a variety of terrains. It also features a modular payload mount with an integrated quick release function that enables operators to mount a dual sensor, a triple sensor, or a multispectral payload effortlessly to suit mission needs. Alongside the aircraft is a GNSS Base Station and the integrated, Dual RTK modules that equip the aircraft with additional redundancy. This allows the Drgonfish Standard to fly confidently in complex environments while capturing precise, centimeter-accurate data.

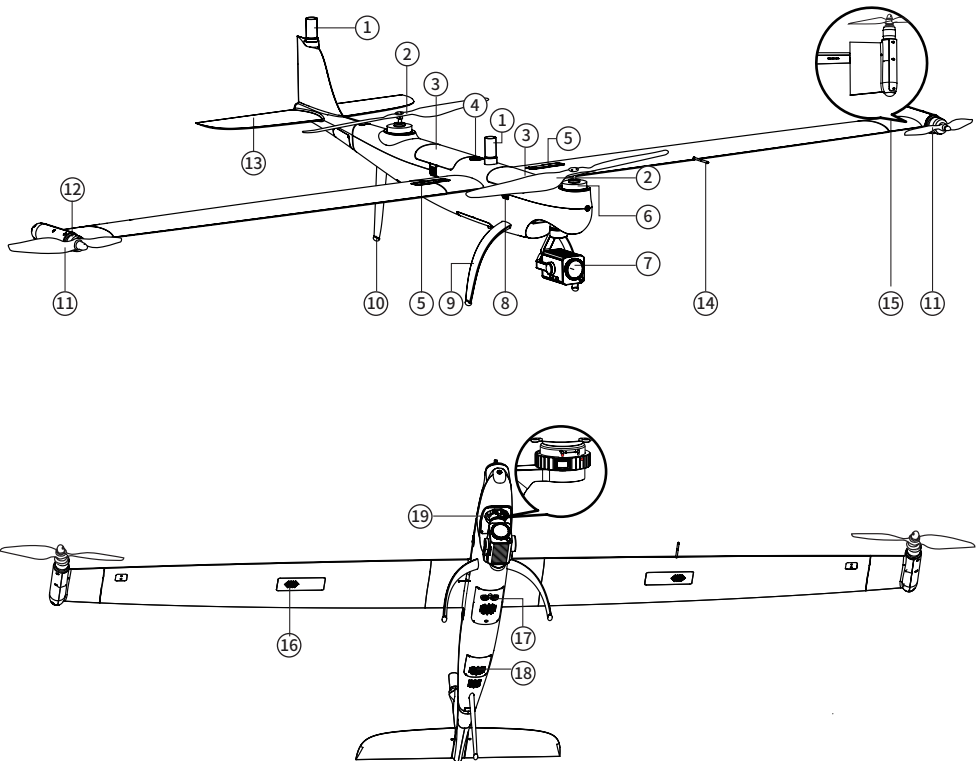

- | | | |
|---------------------------|---------------------------|------------------------------------|
| 1. RTK antenna | 8. Battery release button | 14. Airspeed sensor |
| 2. Propeller blades | 9. Front landing gear | 15. Tilting wingtip |
| 3. Smart battery | 10. Rear landing gear | 16. GPS module |
| 4. Power button/indicator | 11. Wingtip propellers | 17. Ultrasonic Positioning Sensors |
| 5. Wing lock | 12. Wing motor | 18. Dust Net |
| 6. Body motor | 13. Horizontal stabilizer | 19. PTZ installation interface |
| 7. Gimbal camera | | |

Getting to know the portable ground station

The Drgonfish Standard is equipped with a 9.7-inch TFT-LCD touch screen (2048*1536). It offers a brightness of 1000 cd/m², making it almost twice as bright as typical mobile devices. The screen can display images clearly even in direct sunlight, and a built-in 256G memory makes it convenient for storing all your critical data. With an image transmission range of 30km^[1] and a battery life of 4.5 hours, the ground station guarantees optimal performance and reliability.

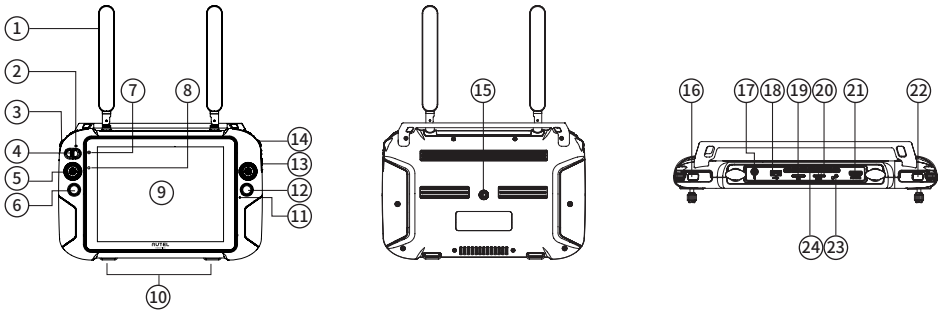

- | | | |
|--------------------------------|---------------------------------|--------------------|
| 1. Antenna | 9. Touch screen | 17. Charging port |
| 2. Mode switch indicator | 10. Hooks (for lanyard support) | 18. USB port |
| 3. Gimbal pitch control wheel | 11. Microphone | 19. SD card slot |
| 4. Manual/Auto mode switch key | 12. Photo/Video button | 20. SIM card slot |
| 5. Joystick | 13. Zoom button | 21. HDMI port |
| 6. Home button | 14. Gimbal level control dial | 22. Custom buttons |
| 7. Power status indicator | 15. Tripod mounting interface | 23. Headphone jack |
| 8. Light perception sensor | 16. Power button | 24. Air outlet |

Getting to know the base station

The Dragonfish base station is a high-precision satellite signal receiver that supports GPS, Beidou, Galileo and GLONASS navigation systems. It can be used across a variety of applications and environments. The Dragonfish base station and the integrated Dual RTK modules equip the aircraft with additional redundancy and positioning accuracy to provide precise, centimeter accurate data. It also enables the Drgonfish Standard to withstand signal interference in strong magnetic environments such as power lines and near buildings.

[1] The experimental data were measured in a non-interference environment

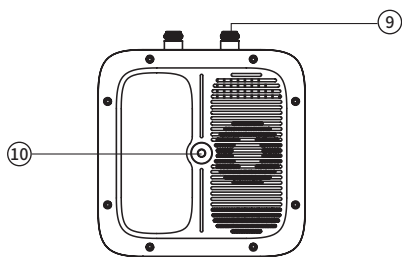
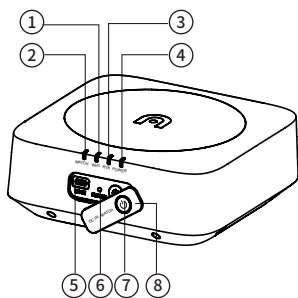

- 1. WiFi indicator
- 2. Linking indicator
- 3. RTK indicator
- 4. Power indicator

- 5. Charging port
- 6. Frequency button
- 7. Power button

- 8. Port cover
- 9. Antenna interface
- 10. Tripod interface

Using the Drgonfish Standard

Charging

1. Charging the Intelligent flight battery

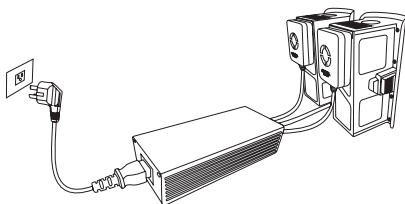

2. Charging the ground station

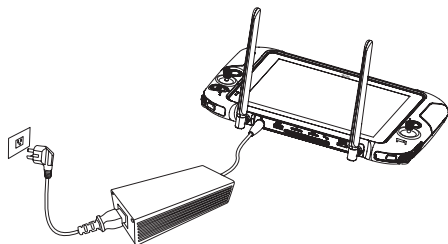

Setting up the base station

1. Unfold the tripod, install the base station tray, and lock the tray.

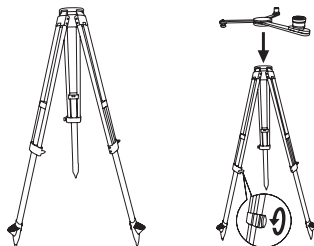

2. Install the base station body to the tray and tighten the lock on the tray nut. Ensure that the base station is level and stable.

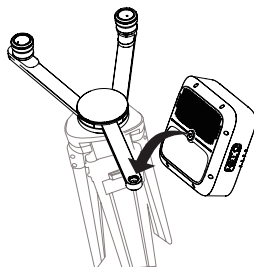

3. Charging the base station

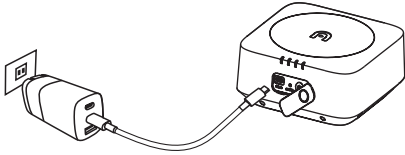

3. Install the antenna on the tripod and connect the antenna feeder to the base station antenna port.

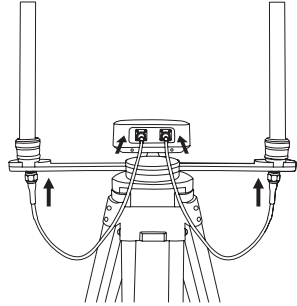

Assembling the aircraft

1. Install the left and right wings

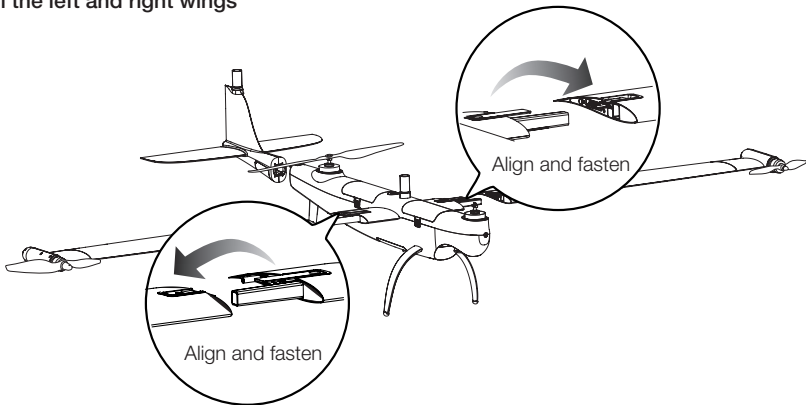

2. Install the tail

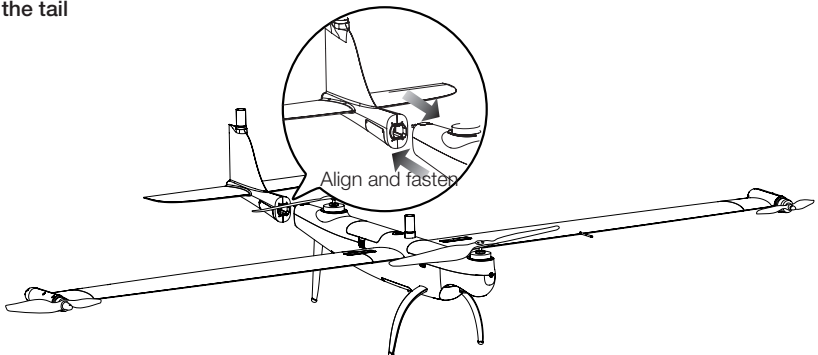

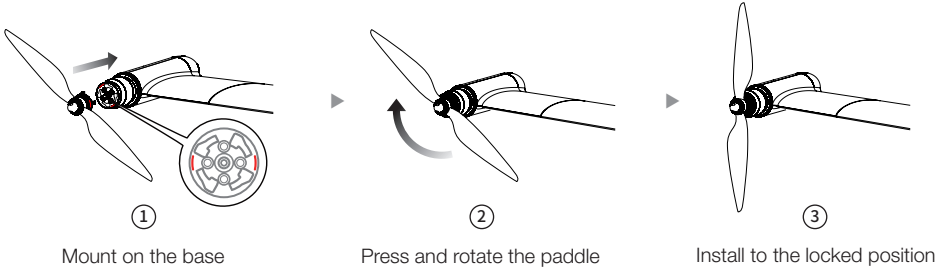

3. Install the wingtip propeller

Before installing or removing the propeller, power off the aircraft (as shown in the illustration).



  Locking direction: Press and Rotate in the indicated direction to lock the propeller.

  Unlocking direction: Press and Rotate the propeller in the opposite direction to unlock it.

 The marked propeller is to be mounted on the marked motor

 Unmarked propeller is to be mounted on the unmarked motor

4. Mounting

Align the red dots on the mount with the red dots of the gimbal interface of the fuselage, and rotate the lock ring to the locked position.

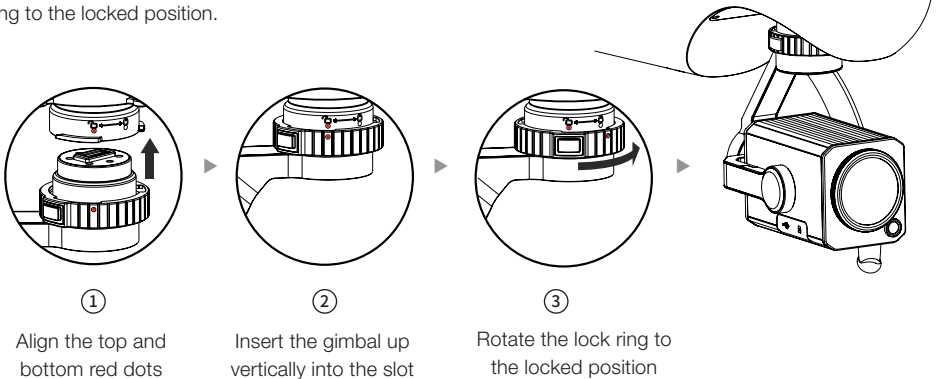

5. Unlock mount

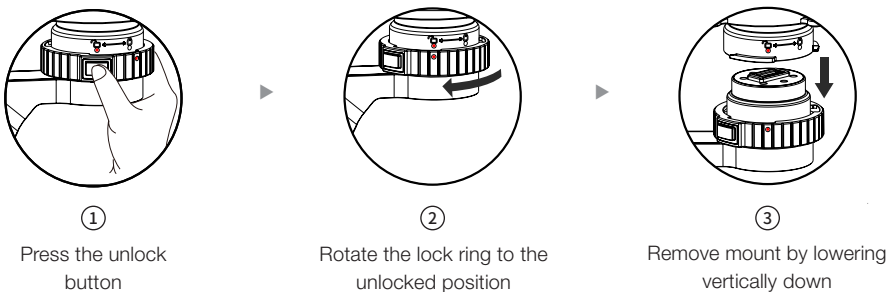

6. Installing the Intelligent Flight Battery

When installing or removing the aircraft battery, be sure to power off the aircraft.

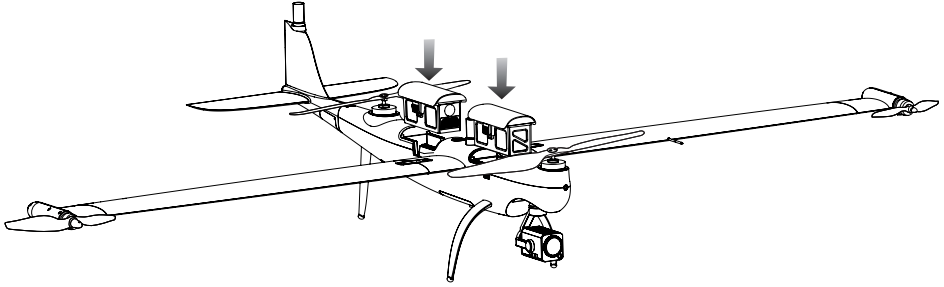

- Align the battery to the battery interface on the fuselage and install it.

Powering on / Activating the aircraft

1. Powering on the base station

Short press the power button for 1 second to turn on the base station.

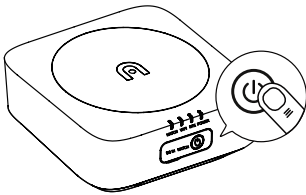

2. Powering on the ground station

Short press the power button for 1 second to turn on the ground station.

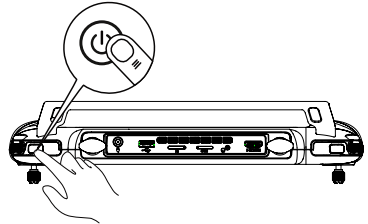

3. Powering on the aircraft

Press the power button on the aircraft body for 3 seconds to power on the aircraft.

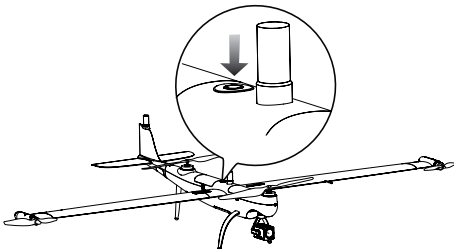

4. Activating the aircraft

Open Autel Voyager and click the activation button to activate the aircraft.

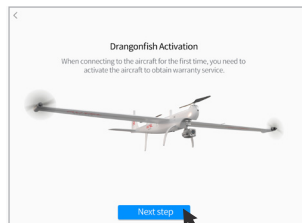

Flight

Enter the Autel Voyager safe flight interface. Before taking off, please place the aircraft on a flat surface with the tail facing towards you.

Manual takeoff

- 1 Switch the ground station gear to M gear.

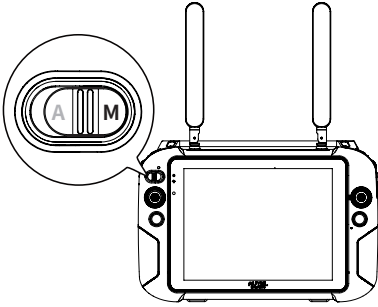

- 2 Check the aircraft system status.

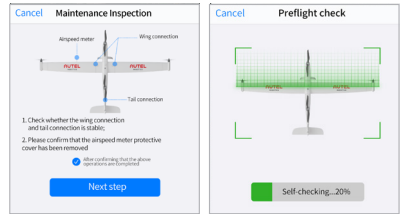

- 3 Simultaneously move the joystick inwards or outwards and hold for 2 seconds to arm the motors.

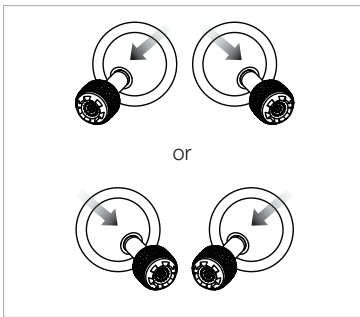

- 4 Push up the left stick (mode 2) to take off.

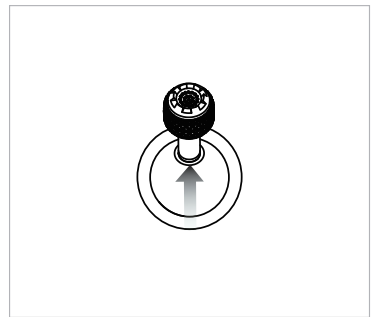

Flight

Enter the Autel Voyager safe flight interface. Before taking off, please place the aircraft on a flat surface with the tail facing towards you.

Automatic takeoff

- ① Switch the ground station gear to A gear

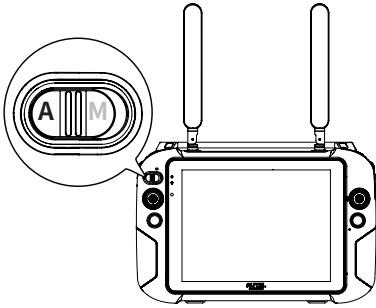

- ② Click the Create Mission button to plan the mission

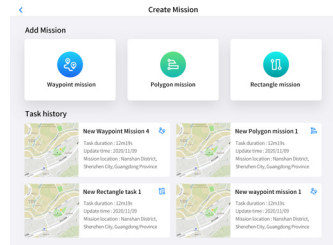

- ③ Aircraft system status check

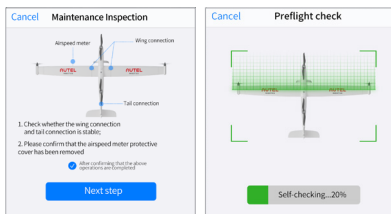

- ④ Flight interface display

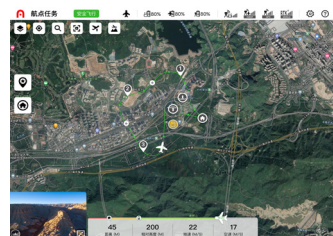

Specifications

Aircraft

Size	2.3*1.29*0.46 m
Weight (including two batteries, without gimbal)	7 kg
Single battery weight	1.3 kg
Maximum load	1.5 kg
Maximum take-off weight	8.5 kg
Working frequency	902-928 MHz,2.4000-2.4835 GHz,5.725-5.755GHz
EIRP (Equivalent radiated power)	900 MHz FCC: <30 dBm 2.4 GHz FCC: <30 dBm SRRC/CE/MIC: <20 dBm; 5.8 GHz SRRC/FCC: <22 dBm CE: < 14 dBm hovering accuracy (P-GPS)
Hovering accuracy (P-GPS)	Vertical: ±0.1 m (when the visual positioning is working normally) ±0.5 m (when GPS is working normally) ±0.1 m (when RTK positioning is working normally) Horizontal: ±0.3 m (when visual positioning is working normally) ±1.5 m (when GPS is working normally) ±0.1 m (when RTK positioning is working normally)
RTK positioning accuracy	During RTK FIX Mode: 1 cm + 1 ppm (horizontal) 1.5 cm + 1 ppm (vertical)
Maximum rotational angular velocity	Pitch axis: 180° /s Yaw axis: 60° /s
Maximum pitch angle	20°
Maximum roll angle	35°
Maximum ascent speed	Vertical flight mode: 4 m/s Fixed-wing flight mode: 5 m/s
Maximum descent speed (vertical)	Vertical flight mode: 3 m/s Fixed-wing flight mode: 5 m/s
Maximum horizontal flight speed	30 m/s
Maximum service altitude	6000 m
Maximum wind resistance	During fixed-wing flight: 15 m/s (level 7 wind)

	Vertical take-off and landing: 12 m/s (level 6 wind)
Maximum flight time	120 min
Supported Payloads	DG-Z2, DG-T3, DG-T3H, DG-L20T, DG-M1
Supported Gimbal Configurations	Fast Disassembly
Ingress Protection Rating	IP43
GNSS	GPS+GLONASS+BeiDou+Galileo
Working temperature	-20° C to 50° C

9.7 inch ground control station

Image transmission parameters:

Maximum transmitting distance (unobstructed, free of interference)	902-928 MHz; 2.4-2.4835 GHz FCC:10 km CE / MIC:5 km SRRC:5 km
--	--

Digital transmission	Working frequency	5.725 - 5.755 GHz
----------------------	-------------------	-------------------

Wi-Fi parameters:	Protocol	Wi-Fi Direct, Wi-Fi Display, 802.11a/g/n/ac Supports 2 x 2 MIMO Wi-Fi
	Working efficiency	2.400 - 2.4835 GHz 5.150 - 5.250 GHz 5.650 - 5.755 GHz 5.725 - 5.850 GHz

Other parameters:	Battery	Name: Lithium polymer Battery Capacity: 8200mAh Voltage: 11.4 V Battery type: Li-Po Energy: 93 Wh Charging time: 120 minutes
	Battery life	Approximately 3 hours (maximum brightness) Approximately 4.5 hours (50% brightness)
	Storage	ROM 256GB + expandable (support TF card)
	Video output interface	HDMI interface

USB-A interface supply voltage/current	5V / 500 mA
Working temperature	-20°C to 40°C
Storage temperature	-20°C to 60°C (within one month) -20°C to 45°C (within three months) -20°C to 30°C (within one year)
Charging environment temperature	0°C to 45°C
Satellite positioning module	GPS+GLONASS+Galileo
Size	319×233×74 mm (antenna folded) 319×398×74 mm (antenna expanded)
Weight	1987 g

Base station

GNSS receiver	Satellite receiving frequency	Simultaneously receive: GPS: L1, L2, L5 BeiDou: B1, B2, B3 GLONASS: F1, F2 Galileo: E1, E5A, E5B
	Positioning accuracy	Single Point Horizontal: 1.5 m (RMS) Vertical: 3.0 m (RMS) RTK Horizontal: 1 cm+1 ppm (RMS) Vertical: 1.5 cm + 1 ppm (RMS) 1 ppm: For every 1 km increase in distance, the accuracy will be 1 mm less. For example, the horizontal accuracy is 1.1 cm when the receiving end is 1 km away from the base station.
	Positioning update rate	1 Hz, 2 Hz, 5 Hz, 10 Hz and 20Hz
	Cold start	< 40 s
	Hot Start	< 10 s
	Recapture Initialization reliability	< 1 s
	Initialization reliability	> 99.9%
	Differential data transmission format	RTCM 2.X/3.X

Communication	Data link	Image transmission, Wi-Fi
Image transmission parameters:	Working efficiency	2.4000-2.4835 GHz; 902-928 MHz
	EIRP (Equivalent radiated power)	902-928 MHz FCC: < 30 dBm 2.400-2.4835 GHz FCC: < 30 dBm SRRC/CE/MIC: < 20 dBm
WIFI parameters:	Working efficiency	2.400-2.4835 GHz 5.125-5.25 GHz 5.650-5.755 GHz 5.725-5.850 GHz
	EIRP (Equivalent radiated power)	2.400-2.4835 GHz FCC: < 26 dBm SRRC/CE/MIC: < 20 dBm 5.125-5.25 GHz FCC/SRRC: < 26 dBm 5.650-5.755 GHz MIC: < 20 dBm 5.725-5.850 GHz SRRC/FCC: < 26 dBm; CE: < 14 dBm SRRC/CE/MIC: < 20 dBm
	Communication distance	Base station and aircraft: 30km (FCC) Base station and ground station: 200m (FCC) (Unobstructed and free of interference, when the mobile station is used as a base station and the distance from the mobile station antenna to the bottom of the tripod is 2 m; and when the difference in height between the remote controller and mobile station is less than 10 m, and when the remote controller is 1.2 m from ground level)
Electrical characteristics	Power consumption	7.5 W
	Power supply	5 to 20V DC
	Battery	Type: Lithium polymer battery Capacity: 4950 mAh Energy: 57.1 WH
	Runtime	>7.5 h
Physical properties	Dimensions (base station body + extension pole)	193 mm×177 mm×73 mm
	Weight	1275 g
	Ingress protection	IP64

Working temperature

-20°C to 50°C

DG-Z2

Zoom camera	Effective Pixels	3840x2160 8M
	Zoom	20x zoom, 12x digital zoom, 240x total magification
	Aperture	F2.0 (wide) to 3.8 (tele)
	Photo Resolution	3840x2160 8M
	Photo	JPEG
	Video Resolution	3840x2160 8M; 1920x1080 20M
	Video	MP4

Wide-angle camera	Effective Pixels	4000x3000 12MP
	Zoom	1-8x digital zoom
	Photo Resolution	4000x3000 12MP
	Photo	JPEG
	Video Resolution	3840x2160 8M; 1920x1080 20MP
	Video	MP4

DG-T3

Zoom camera	Effective Pixels	3840x2160 8M
	Zoom	20x zoom, 12x digital zoom, 240x total magification
	Aperture	F2.0 (wide) to 3.8 (tele)
	Photo Resolution	3840x2160 8M
	Photo	JPEG
	Video Resolution	3840x2160 8M; 1920x1080 20M
	Video	MP4

Wide-angle camera	Effective Pixels	4000x3000 12M
	Zoom	1-8x digital zoom

Photo Resolution	4000x3000 12M
Photo	JPEG
Video Resolution	3840x2160 8M; 1920x1080 20M
Video	MP4

Thermal Camera	Infrared camera sensor	Uncooled VOx Microbolometer
	Sensor Resolution	640*512
	Zoom	1-8x digital zoom
	Pixel Pitch	12μm
	Spectral Band	8-14μm
	Lens	25mm F1.0
	FOV	17°x14°
	Photo Resolution	640*512
	Photo	JPEG
	Video Resolution	640*512
	Frame Rate	30Hz
	Video	MP4
	Accuracy	±3°C or ±3% of reading (whichever is greater) @ambient temperature -20°C ~60°C
	Scene Range	High Gain: -20° to +150°C Low Gain: 0°to +550°C

 **NOTE:**

This content may be updated without prior notice. You can check the latest version on the official website of Autel Robotics at www.autelrobotics.com



WWW.AUTELROBOTICS.COM

© 2021-2022 Autel Robotics Co., Ltd. All Rights Reserved